

Accessories and Upgrades

- AN0010** Additional interior siren.
- SCL2202** 2 wire motor for single point locking (CDL will not operate from the passenger door).
- AN0021** Ultrasonic detector (for AN411 and 412). Protects the interior of the vehicle.
- AN0027** Total close timer. For vehicles fitted with total close on the door lock circuit. This unit will close the electric windows and sunroof if the vehicle is equipped with total close
- AN0031** Electric window interface. This unit will close two electric windows when the alarm is armed
- SWK9000** Electric window kit. These will convert any pair of manually operated windows to electric.
- MP2000** Single zone pager. 400m range alerts when the siren is sounding.
- MP4000** Rechargeable 3 zone pager. 1Km range. Alerts you when the alarm is sounding.
- PP901** Digitalk system. Incorporating a Dual Zone Microwave to protect the interior and exterior of the vehicle an has a voice warn away message.
- AN0055** Spare self coding remote control

All these accessories and upgrades are available from your local MicroSCAN dealer.

TECHNICAL HELPLINE
IF YOU ENCOUNTER ANY
DIFFICULTIES INSTALLING THIS
ALARM, PLEASE TELEPHONE OUR
TECHNICAL HELPLINE

ON
01244-321700
 MONDAY TO FRIDAY
 10am to 4.30pm

PERFORMANCE PRODUCTS LTD

advanced TECHNOLOGY

Clever House, 8 Boughton, Chester, CH3 5AG.

Tel:-01244 321300. Fax:-01244 343370. **HELPLINE:-01244 321700 (Mon - Fri 10am till 4.30pm)**
 AN400 003 01/00

Micro|S|C|A|N/ SECURITY PRODUCTS

AN400 MODULAR SECURITY SYSTEM

INTRODUCTION.

The AN400 series of alarms offers instant protection for your vehicle day and night. The integrated 'double guard shock sensor will monitor the vehicle perimeter and detect impacts or blows to it. Also incorporated is an ignition sensing circuit and a negative trigger circuit, which will sound the alarm if the doors are opened. Standard features include integral central door locking interface, two encrypted 'code hopping' remote controls, visual confirmation of ARM and DIS-ARM via the indicators.

The AN402 and AN403 come with interior sensors as standard. The AN401 can be upgraded by adding an interior sensing device such as ultrasonic or a microwave.

Accessories such as total closure units and/or pager systems can be added to any of the alarms in the range (see page 12 for a full list of options available).

Please familiarise yourself with the operating instructions before using this security system.

OPERATING INSTRUCTIONS.

ARMING

To ARM the system press button A on the transmitter, the siren should chirp once and the indicators should flash once to confirm arming. The doors will lock (if CDL is fitted and the status LED should begin to flash.

DISARMING

To DISARM the system press button A on the transmitter, the doors will unlock and the status LED will stop flashing. The siren should chirp twice and the indicators will flash three times to confirm disarming (if the siren chirps more than twice the alarm has been triggered in your absence).

STATUS LED

If the alarm has been triggered the status LED will indicate which circuit has been violated. See the table below for details. To cancel the status LED switch On the ignition.

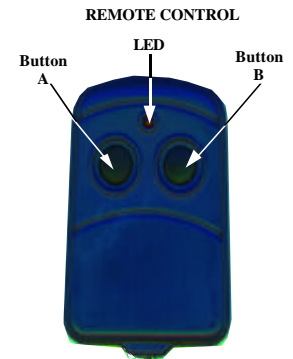

STATUS	LED
DISARMED	OFF
ARMED	FLASHING SLOWLY
TRIGGERED	FLASHING TWICE PER SECOND
PASSIVE ARMING**	FLASHING RAPIDLY
VALET MODE OR TRANSMITTER PROGRAMMING MODE	ON CONSTANT

** If programmed

ADVANCED OPERATION

Depending on your choice and level of installation the AN400 series can be programmed to offer the following features :-

- Keyless entry** If the vehicle is equipped with central door locking the alarm can lock and unlock the doors when the system is armed and disarmed.
- Anti car Hi -jacking** If the vehicle is equipped with central door locking the doors will lock automatically when the ignition is switched On and unlock when the ignition is switched Off
This feature is programmed during the installation.
- Passive arming** The alarm will automatically ARM 30 seconds after the ignition is switched Off and the drivers door is closed.
This feature is programmed during the installation.
- Passive door locking** When the alarm passively ARMS the doors will also lock and, if electric window closures are fitted, the windows will close. *Always remove the keys and transmitter from the vehicle before exiting.*
This feature is programmed during the installation.
- Auto Re-arm** If the system is programmed for passive arming and the system is DISARMED and the ignition is not switched On, the system will ARM itself after 30 seconds.
This feature is programmed during the installation.
- Interior light delay** When the alarm is DISARMED the interior light will stay illuminated for 30 seconds, or until the ignition is switched On.
This feature is programmed during the installation.
- Valet mode** If the system is programmed with the passive arm feature, the valet mode will put the system on 'hold'. The remote control CDL, panic and indicator flash will still operate. This feature is ideal for vehicle servicing.
- Permanent chirp delete** The audible tone on arm and disarm can be deleted.
This feature is programmed during the installation.
- Alarm activation warning** If the alarm has been triggered in your absence the siren will chirp four times when the system is DISARMED and the status LED will remain On. See the chart on page 1 for details.

EMERGENCY OVERRIDE.

If the transmitter is lost or the battery is discharged the alarm system can be overridden via the ignition switch. To override the system :-

- 1) Open the drivers door, the alarm will sound.
- 2) Switch the ignition On and Off seven times at 1 second intervals, this must be done within 10 seconds of the door being opened. The alarm is now DISARMED.

ADJUSTMENT OF THE DETECTORS.

The system must be ARMED to adjust the sensors.

Shock sensor.

The adjustment screw can be located on the rear of the control unit. To increase the sensitivity rotate the adjuster CLOCKWISE.

Adjustment :-

- 1) Arm the system and wait for 15 seconds.
- 2) Apply a light impact to the vehicle, the siren should chirp 5 times. If it does not increase the sensitivity of the shock sensor.
- 3) Once the shock sensor is set, you should test the second stage of the shock sensor by rearming the system and applying a heavy impact, the siren should now sound. If the siren only chirps the shock sensor may require further adjustment.

Ultrasonic sensor.

The Ultrasonics are *self adjusting*, so once the sensors are mounted and the control unit is connected to the alarm module, nothing further needs to be done.

Single zone microwave.

The adjustment screw on the microwave can be located on the top of the microwave unit, the LED will illuminate when the sensor is violated. To increase the sensitivity of the microwave, rotate the adjuster clockwise.

Adjustment of microwave.

- 1) Open both the drivers and passenger windows.
- 2) Arm the system and wait for 15 seconds.
- 3) Lean into to vehicle, the siren should sound. If the siren does not sound, disarm the system and rotate the adjuster clockwise.
- 4) Repeat the test and readjust the sensitivity until the siren sounds.
- 5) Once the level is set close all the windows and rearm the system.
- 6) Now walk around the perimeter of the vehicle touching all the windows, including the sunroof and front windscreen, the siren should not sound. If the siren does sound reduce the sensitivity of microwave.
- 7) Refit any trims that cover the microwave and repeat the test, the sensor may require re-adjustment.

THE MOST COMMON CAUSE OF FALSE ALARMS IS THE INCORRECT ADJUSTMENT OF THE SENSORS. PLEASE TAKE A FEW EXTRA MINUTES TO ADJUST THE SENSORS CORRECTLY.

Now the installation is complete all the panels and trims should be refitted and the alarm system re-tested.

Also check that the electrical equipment such as wipers, headlights, indicators etc operate correctly.

IF YOU ENCOUNTER ANY DIFFICULTIES INSTALLING THIS ALARM PLEASE TELEPHONE OUR TECHNICAL HELP LINE ON 01244-321700

PROGRAMMING FEATURES.

To programme the features on the AN400 series remove the 'jumpers' from the rear of the control unit.



Disconnect the power from the alarm **BEFORE** removing or inserting the 'jumpers'.

Jumper No	Programmable feature (Remove Jumper to programme)
1	Extends the CDL lock pulse to 3.5 seconds (for vacuum CDL)
2	Deletes the siren chirp on ARM and DISARM
3	Activates the passive locking feature
4	Deletes anti car hi - jacking (automatic door locking when the ignition is switched On).
5	Activates passive ARMING

SHOCK SENSOR.

For the optimum performance of the two stage shock sensor the control unit must be securely mounted on a firm base, as near to the centre of the vehicle as possible. The ideal position would be on the bulkhead behind the dashboard area.

Siren Connections.

There are four different types of siren are available, single and six tone battery back-up and single and six tone non battery-back up. The sirens should be connected as follows are:-

Single and six tone non battery back – up (AN0003 and AN0005)

Red Wire Connect to **WHITE** wire from the alarm

Black wire Connect the clean chassis earth.

Single and six tone battery back – up (AN0004 and AN0006)

Red wire Connect to Permanent 12v fused supply.

Black wire Connect to clean chassis earth.

Purple wire Connect to the **WHITE** wire from the alarm.

Blue wire This wire is not used.

PROGRAMMING NEW TRANSMITTERS.

It is possible to program up to 3 transmitters. It is important that whenever the programming is

undertaken that **ALL** the transmitters that are required to operate the alarm are available at the time of programming. To programme the transmitters follow the procedure below :-

- 1) Disarm the alarm.
- 2) Remove the 15A fuse which protects the alarm.
- 3) Replace the fuse and within 10 seconds switch the ignition On and Off three times, finishing with the ignition in the On position.
- 4) The siren will chirp once and the status LED will be On but not flashing, indicating the system is in programming mode.
- 5) Press button **A** on the first remote control, the siren will chirp once.
- 6) Press button **B** on the second remote control, the siren will chirp twice.
- 7) If you have a third transmitter press buttons **A** and **B** simultaneously, the siren will chirp three times.
- 8) To exit the programming mode, switch Off the ignition.

TRANSMITTER FUNCTIONS

FUNCTIONS	BUTTON	ORIGINAL STATUS	CONFIRMATION
ARM	A	DISARMED	1 chirp / 1 flash Door lock
DISARM	A	ARMED	2 chirps / 3 flashes Doors unlock
ARM CHIRP DELETE	B then A	DISARMED	1 flash Doors lock
DISARM CHIRP DELETE	B then A	ARMED	3 flashes Doors unlock
INTERNAL SENSOR DELETE	A then A within 3 seconds	ARMED	1 extra chirp and flash
EMERGENCY PANIC	A and hold it down for 3 seconds	ANYTIME	Siren sounds and indicators flash for 30 seconds
VALET MODE	A and B simultaneously for 3 seconds	DISARMED WITH THE IGNITION ON	1 chirp
EXIT VALET	A and B simultaneously for 3 seconds	VALET MODE IGNITION ON	2 chirp

TRANSMITTER BATTERY REPLACEMENT.

If the range of the transmitter deteriorates the battery may require replacing. The battery type is -12v 23A alkaline ISO part No GP23A.

To replace the battery remove the screw on the rear of the transmitter and prise the case apart. Remove the old battery and replace it with a new one ensuring the correct polarity.

INSTALLATION INSTRUCTIONS.

Please read the installation instructions carefully before starting the installation, if you have any question relating to the installation please call 01244 321 700.

Alarm control unit.

The control unit should be located in a suitable behind the dashboard. The unit should be mounted away from direct heat and clear of any moving parts and electronic control modules, such as electronic ignition modules and SRS airbag ECU.

Status LED.

The LED should be located in a spare switch blank, ideally in the centre of the dashboard so it is visible from both sides of the car.

Remove the blank and drill a 8mm hole in the blank, firmly push the body of the LED into the hole until it is fully seated. The LED comes with a pre-wired loom which plugs into the alarm control unit.

Ultrasonic detectors - AN403, AN413, AN423 & AN433 only.

The ultrasonic will detect any air movement inside the vehicle, so it is important that the Windows and fresh air vents are firmly closed to prevent false alarms.

The ultrasonic sensors should be mounted on the 'A' pillar as high up as possible, at least 30cm from the air-vents. They should be angled towards the centre of the rear windscreen.

Once the sensors are mounted the cables should be routed down the pillar to the control unit, which should be fitted behind the dash area. **The Black ultrasonic cables must not be cut or extended.**

Single zone microwave - AN402, AN412, AN422 & AN432 only.

A microwave sensor emits a symmetrical 'bubble of radar' inside the interior of the vehicle, so the mounting position is very important. The microwave should be positioned in the centre of the passenger compartment, ideally between the two front seats or between the head lining and the roof.

The LED should face towards the area to be protected.

The radar will pass through glass, plastic and wood but **not** metal, so it can be fitted below the centre console.

The microwave has a 3 wire loom which connects the Microwave to the Alarm, the **RED** plug connects to the alarm module and the **WHITE** plug connect to the microwave.

Siren.

The siren should be mounted in the engine bay, away from direct heat and water spray. The ideal location is on the bulkhead or on the inner wing.

Remove the bracket from the siren, and using the bracket as a template drill two 3mm holes (protect the holes with a rust proofing agent), secure the bracket using the screws provided and fit the siren to the bracket.

Route the cable from the siren into the interior of the vehicle and connect to the control unit.

The Black wire from the siren should be connected to a clean chassis earth.

ULTRASONIC DETECTOR AN403, AN413, AN423 & AN433 ONLY

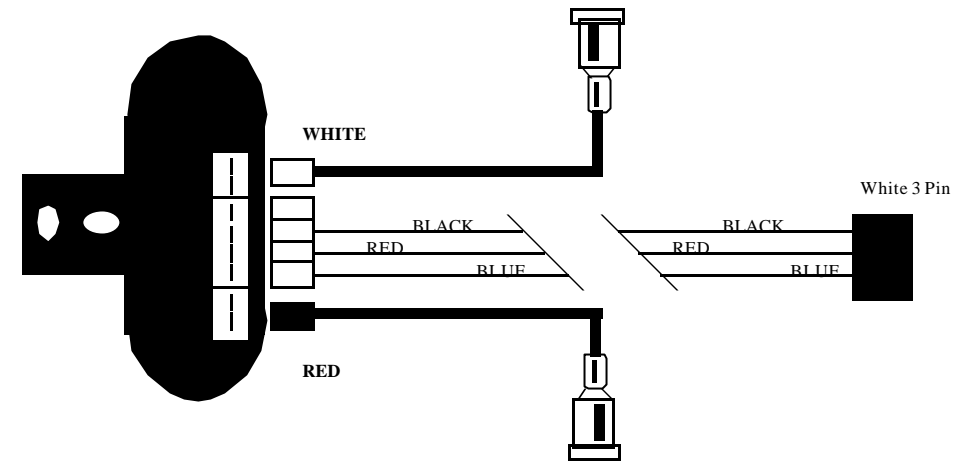

MICROWAVE DETECTOR - AN402, AN412, AN422 & AN432 ONLY

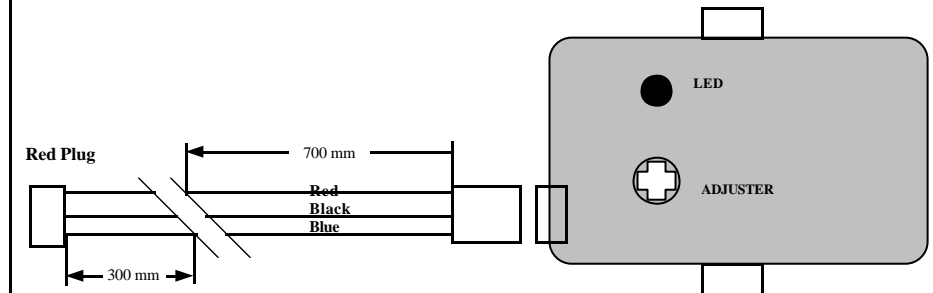

Important: The two plugs above appear to be the same but they are configured **differently**. The Red plug must be plugged into the Alarm and the White plug must always be plugged into the MICROWAVE sensor

OPTIONAL INTERIOR LIGHT DELAY

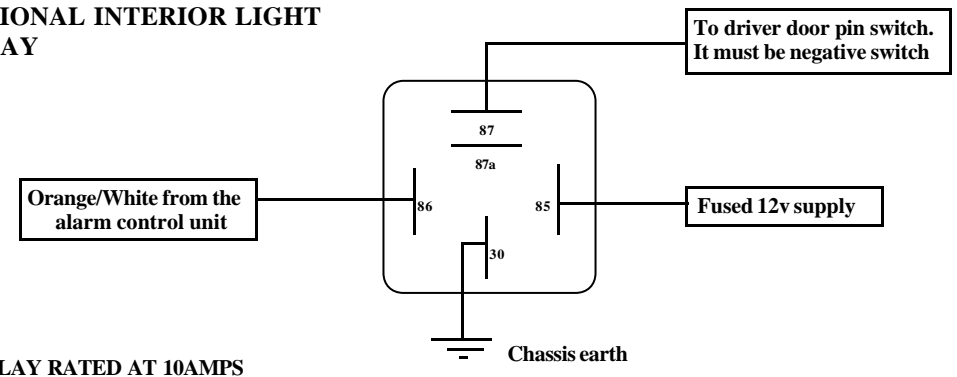

RELAY RATED AT 10AMPS

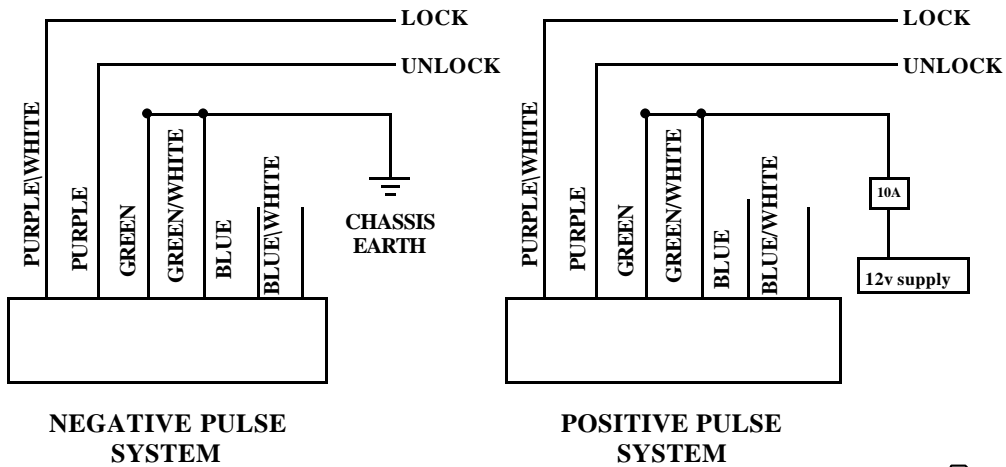

BLUE AND BLUE/WHITE WIRES ARE NOT CONNECTED FOR NEGATIVE AND POSITIVE LOCKING SYSTEM.

Always use the fuses illustrated

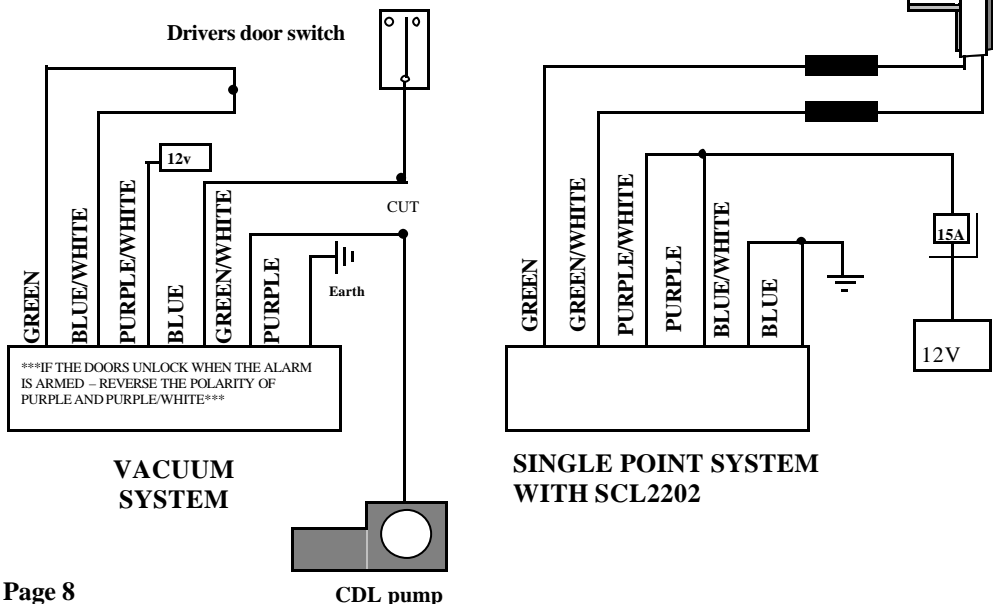

WIRING INSTRUCTIONS.

Alarm control unit.

- Black aerial** Do not cut or extend this wire. Route away from metal objects and electronic ECUs.
- Black wire** Connect to good chassis earth.
- Red wire** 12v positive input. Connect to permanent **UN-fused** 12v supply. The supply must be rated at 15A, the ideal location would be at the main fusebox.
- Grey wire** 12v output for the indicator flash. Connect to either the left or right indicator circuit. The best location would be at hazard switch or the indicator switch
- Grey wire** 12v output for the indicator flash. Connect to either the left or right indicator circuit. The best location would be the hazard switch or the indicator switch.
- Red/White wire** Ignition sense input. Connect to an ignition supply that is positive when the ignition is **On** and when the engine is **cranking**. The ideal location would be at the rear of the ignition switch.
- Yellow wire** 12v negative output when the alarm is ARMED - max 500mA. Connect to additional interfaces such as window closures etc.
- White wire** 12v positive when the alarm is sounding. Connect to the siren input. This wire can also be connected to an internal siren and/or a pager system.
- Brown wire** Negative trigger input. This wire should be connected to the drivers door pin switch and the bonnet switch.

6 Pin Central Door Locking plug.

Blue, Green, purple, Blue/White, Green/White and Purple/White - Refer the the central door locking diagram on page 8 for connection details.

3 Pin connection.

Interior sensor connecting. This is for connecting the interior sensors such as ultrasonic or micro-wave to the control unit.

SCHEMATIC WIRING DIAGRAM

Plug layouts are for illustration purposes only

**ALL CONNECTIONS MUST BE
SOLDERED AND INSULATED**

